

GARAGE PERMIT

POST THIS APPLICATION IN FRONT WINDOW DURING CONSTRUCTION

CITY OF HICKORY HILLS
Application For Garage Permit

(Please fill out and submit **two (2)** copies of this form.)

Permit # _____

Approved by Gordon Betcher

Date _____

Fee \$255.00

(Fee and Inspection Included)

Application is hereby made for a garage permit

Owner: _____

Address: _____

Hickory Hills, IL 60457

Phone: _____

Contractor: _____

R.E. Index: _____

Estimated Cost of Construction: _____

All attached garages in residential zoning districts shall not exceed 900 s.f. or more than 3 garage spaces. All detached garages in residential zoning districts shall not exceed 900 s.f. in area, have more than 2 garage spaces, nor have a garage door opening exceeding 8 feet in height. The height of a detached garage shall not exceed 16 feet or the height of the main building on the zoning lot, whichever is lesser, but the height of the garage may be at least 12 feet in any event. Only one detached garage shall be allowed for each single family dwelling or on any one residential zoning lot. No garage shall be located closer than 10 feet to any structure located on the lot. No garage shall be erected within 3 feet of any side yard lot line, within 5 feet of any rear yard lot line, within 15 feet of any street or in such manner that any portion of the garage extends past the front of the principal structure on the lot.

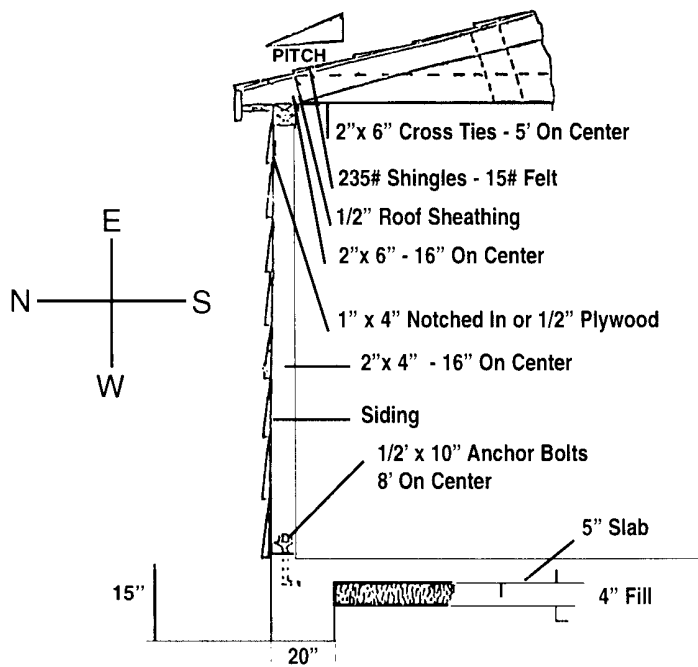
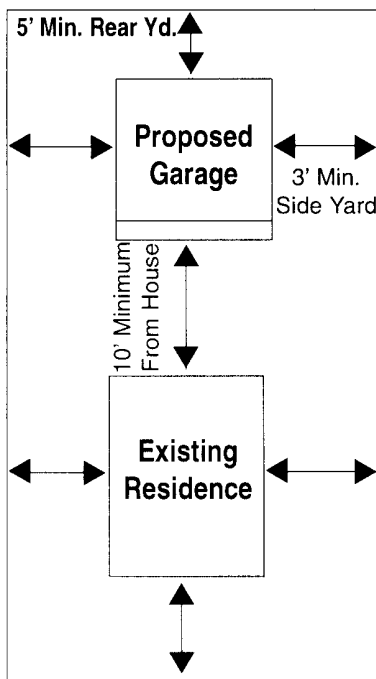
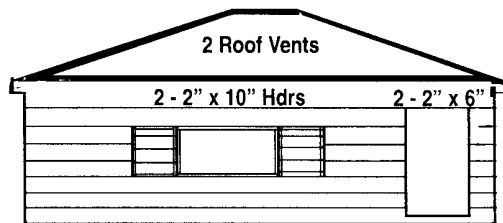
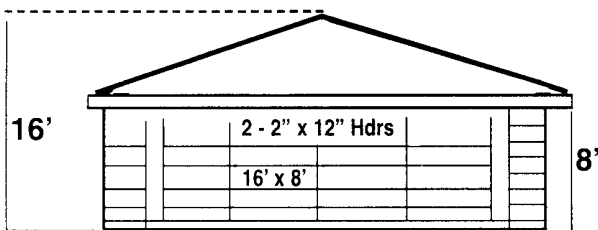

(Please fill out and submit **two (2)** copies of this form.)